



MotoSafe®

MSE of Canada Ltd.

INSULATION MONITOR FOR LOW VOLTAGE ELECTRICAL MACHINES TYPE MG600 MODEL M603INDS

MotoSafe Type MG600 Model M603INDS Insulation Monitors are primarily intended for use in special applications such as variable speed or soft start drives or solid-state contactors to monitor AC motors with line voltages to 600 volts. They may also be used with DC motors to 600 volts. The insulation resistance range of 5 Megohms to 1 Megohm was chosen to meet industrial environmental requirements. They provide visual alarm indication, with contacts for external alarm and other functions.

APPLICATION:

- ◆ Easy Installation
- ◆ Small footprint DIN Rail Mounting
- ◆ Completely automatic in operation
- ◆ Early warning of insulation problems
- ◆ Solid state circuitry
- ◆ Low monitoring voltage for personnel safety
- ◆ Integral self-test capability
- ◆ LED local alarm
- ◆ Contacts provided for local alarm and PLC connection
- ◆ Optional automatic reset mode
- ◆ Usable with variable speed drives



APPLICATION:

MotoSafe Model M603INDS Insulation Monitors provide safe monitoring of electrical motor insulation integrity in all environments. Their primary application is on motors which are in intermittent operation, as these motors are the most susceptible to insulation deterioration in adverse environments. Designed for use with variable speed drive AC motors and motors with soft start or solid-state contactors up to 600 volts, they may also be used with DC motors to 600 volts. MotoSafe Model M603INDS Insulation Monitors give **early warning** of insulation degradation long before the motors are in danger of failing on start up. This allows preventative maintenance to be scheduled when convenient, thus eliminating motor insulation failure as a cause of production downtime, product loss or emergency situations.

When used with variable speed drives, soft start or solid state contactor, an isolation contactor is required for complete isolation of the motor from the power line when it is off-line. The isolation voltage (range 24 - 600 volts AC/DC) must be obtained from a source, such as the running light, which is energized simultaneously with the drive or incoming power to the drive. Model M603INDS offers easy meggering of the motor winding and has three alarm levels (5, 3 and 1 MΩ), selectable with a faceplate switch, to provide a simple way of insulation deterioration rate determination by noting the time intervals between alarms at successively lower levels.

Model M603INDS monitors are designed to monitor insulation resistance to 10MΩ. For higher settings with low voltage motors the MotoSafe Model LM602IND is recommended.

ORDERING INFORMATION:

- Order MotoSafe Model M603INDS and specify the required control voltage.
- Installation Kit IK-MGM includes: Explanatory and Warning labels, the bracket DIN-MGM, the flashing alarm light FAL, a Test Resistor and hook-up wire, wire connectors, Ty-wraps and mounting screws to install the unit,.

SPECIFICATIONS:

Model M603INDS

| | |
|-------------------------------|---------------------------------------|
| Max Line Voltage | 600 AC/DC |
| Supply Voltage* | 115 or 230v. AC, +20 -40% 50/60 Hz |
| Power Requirements | 3 va. |
| Factory Set point** | 5, 3 & 1 Megohms |
| Isolation Voltage | 24 – 600V AC/DC |
| Isolation time | 0.5 ms |
| Contact Rating | 5 amp., 250 v. AC resistive |
| Dimensions (mm) WxHxL (in) | 45 x 68 x 112 1.77 x 2.67 x 4.4 |
| Weight (kg)/(oz) | 0.27/9.5 |

* DC and 400Hz supply voltages available – contact factory.

** For other set points, consult factory.

- Maximum short circuit current 5 microamps.

- Operating temperature -20°C to +50°C; storage temperature -40°C to +100°C.

- Environment; maximum 95% relative humidity, non-condensing.

- UL and CSA Approved as Industrial Control devices.

CONNECTION DIAGRAM – MODEL M603INDS

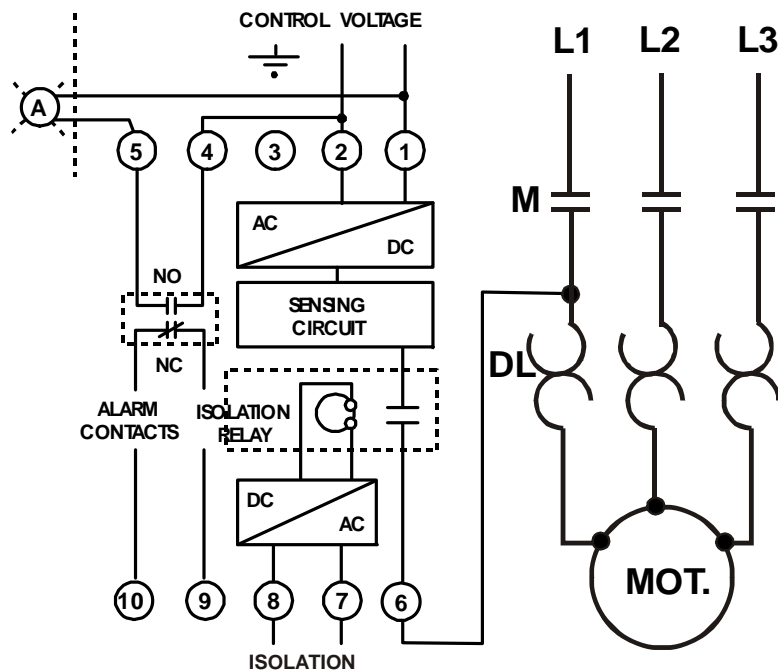

MotoSafe™ MONITOR TYPE M603INDS; INSTALLATION

IMPORTANT: READ THE FOLLOWING INSTRUCTIONS BEFORE INSTALLING THE MONITOR!

The MotoSafe device continuously monitors the insulation resistance of idle machines to provide early warning of insulation deterioration. It withstands test voltages up to 1000V.

INSTALLATION

1. Disconnect power from the starter unit.
2. Install the mounting bracket close to the enclosure hinges using the screws supplied. Clip the monitor securely to the mounting bracket.
3. If required and regulations permit, install the long life flashing alarm light (supplied) on the starter enclosure front panel close to the hinges and affix the self-adhesive warning label around the lamp.
4. Connect terminals 1 & 2 to the specified control voltage. Connect terminal 6 to any phase on the load side of the main contactor (or the final running contactor if not direct on-line starting). Connect terminal 3 to ground.
5. Connect terminals 7 & 8 to running lights or the load of the main contactor.

Use terminals 9 & 10 for start prevention (if required) and terminals 4 & 5 for local or remote alarm operation.

INITIAL TEST PROCEDURE

1. Ground one of the motor phases momentarily with the supplied Test Resistor
2. The Red LED should light and the external alarm circuit be activated after a delay of 8 – 10 seconds.
3. Reset the monitor with the RESET button.
4. Repeat the procedure with the other two phases.

Monitoring is now automatic and may be verified at any time by pressing the TEST button.

CONNECTION DIAGRAM MODEL M603INDS

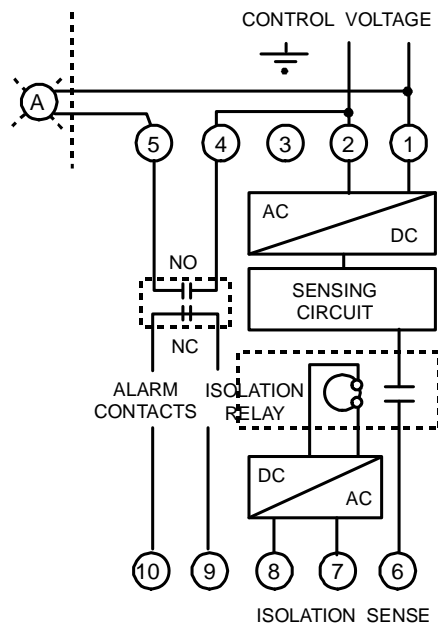

NB. If the motor is wired for start prevention it will be tripped out by the test.

Alarm level switch: recommended initial setting is 5 Megohm; however if still in alarm at 1 Megohm, call for service!

SPECIFICATIONS

| | |
|-------------------|--|
| Control voltage | 115/220V AC + 20 -40% 50/60 Hz \pm 10%, 3VA |
| Max. Line voltage | 600V AC/DC |
| Isolation voltage | 24 - 600V AC/DC |
| Isolation time | 0.5 ms |
| Measuring current | 50 μ A max. |
| Contacts rating | 250V 5A AC resistive |
| Dimensions | 4.4" x 1.77" x 2.67" 112 x 45 x 68 mm |

Available for DC control, 400Hz and different settings – consult factory

NOTE: DISCONNECT CONTROL POWER FROM THE STARTER ENCLOSURE IF HIGH VOLTAGE INSULATION TEST IS REQUIRED.