



MEDIUM VOLTAGE AC ELECTRICAL MACHINES INSULATION MONITOR TYPE MHV

Type MHV Insulation Monitors are designed to monitor Medium Voltage AC motor installations for insulation deterioration whenever they are not energized. In such installations personnel safety is paramount and Type MHV Monitors incorporate features to maximize that safety. They are entirely automatic in operation and are CSA Certified and UL Listing as High Voltage Industrial Control Devices.

FEATURES:

- ◆ Easy Installation
- ◆ Cover voltages to 13.8 KV AC 3 phase
- ◆ Surge capacitor discharge delay included
- ◆ Residual voltage forced discharge circuit
- ◆ Vacuum contactor rated
- ◆ Low test voltage for personnel safety
- ◆ Completely automatic operation
- ◆ Solid state circuitry
- ◆ High / Low alarm selection
- ◆ LED local alarm / remote alarm capability
- ◆ Local / Remote test and reset capability
- ◆ Actual resistance reading output
- ◆ Small footprint DIN rail mounting

APPLICATION:

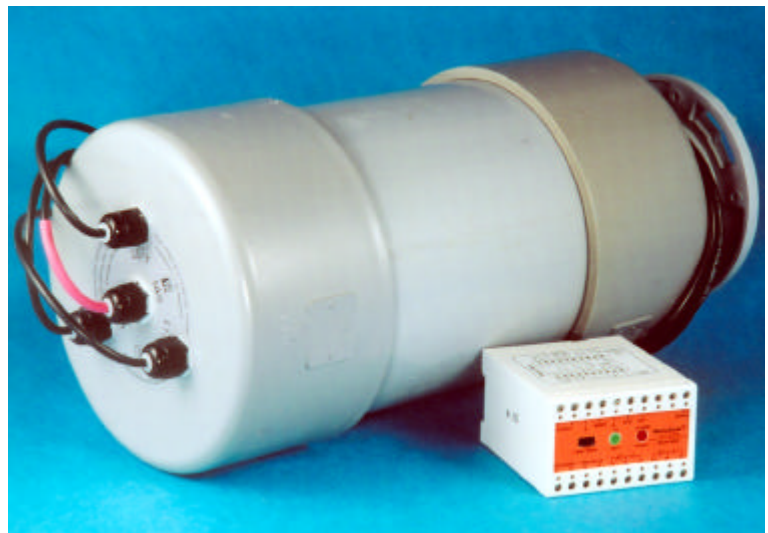

MotoSafe Insulation Monitors are designed to provide safe monitoring of the electrical insulation integrity of electrical machines and equipment whenever they are not in use. Their primary use is to monitor machines which are in intermittent service, to give early warning of the insulation deterioration which precedes failure, as starting and stopping machines causes micro cracking of the insulation with consequent degradation of its properties.

The Type MHV Insulation Monitor is intended for use with medium voltage motors to 13.8 kV. To maximize personnel safety they use a low DC voltage to sense insulation resistance and they are connected to the motor circuit through the star point of a high resistance Intermediate Resistor Block (IRB). Under normal circumstances this ensures that the Sense terminal is at ground potential and should a ground fault occur on the motor supply, the impedance of the Intermediate Resistor Block limits the Sense terminal voltage to a safe level.

Type MHV monitors incorporate features to allow the complete discharge of surge capacitors and the dissipation of residual charge in motor cabling, to eliminate possible nuisance alarms. The monitor is equipped with analogue output which provides the actual value of the insulation resistance in the range of 0 to 70 Megohm.

To eliminate the hazard to personnel, the connection between the Intermediate Resistor Block in the high voltage compartment and the MHV monitor unit in the low voltage compartment of the motor control gear, is current limited by the high internal impedance of the Intermediate Resistor Block to a maximum of 1.4 milliamperes, i.e. 28% of the mandated GFCI trip level. This maximum current flows through the "Sense" line (the red conductor of the IRB) to terminal # 10 of the MHV monitor unit only if terminal 10 is shorted to ground when a ground fault exists on one phase of the motor supply.

ORDERING INFORMATION

- a) Refer to the specifications and include the line and control voltage required. Example: for 13.8kV max. motor with 120V control, order MHV-13800-120.
- b) Installation Kit IK-MHV includes: Explanatory and Warning labels, the DIN-MHV and IRB brackets, the flashing alarm light, a Test Resistor, hook-up wire, wire connectors, Ty-wraps and mounting screws sufficient to install the unit. (The resistance indicating panel meter is sold separately).

SPECIFICATIONS

MotoSafe Type MHV Medium Voltage Insulation Monitors

Parameter	Model	MHV-13800	IRB-13800
Line voltage max.		N/A	13.8kV AC
Control voltage*		120 or 220 V, ±20%, 50/60Hz	N/A
Control power		3 VA	N/A
Isolation voltage		24 - 300 V AC/DC	N/A
Factory Setpoints**		Low - 14 MΩ; High - 20 MΩ	N/A
Contacts rating		5 A, 250 V AC, resistive	N/A
Isolation time		0.5 ms	N/A
Dimension (mm) WxHxL (in)		103x68x112 4.05x2.67x4.4	238Øx500 9.4Øx19.7
Weight (kg) / (oz)		0.44 / 15.5	7.7 / 270

* DC and 400Hz control voltages available - contact factory

** For other Setpoints - contact factory

- Available for monitoring on-line equipment - contact factory
- May be equipped with optional panel meter PM-70
- All units suitable for DIN Rail Mounting.
- Maximum short circuit current is 1 microampere.
- Temperature: operating -20° to +50°C; storage -40°C to +100°C.
- Environment maximum 95% relative humidity, non-condensing.
- UL and CSA approved.

The MHV monitor available in two versions of the analogue output voltage in relation to the resistance:

R _i MΩ	0	1	3	5	7	10	15	20	25	30	40	50	60	70
U _{7ver.1} V	0	0.66	1.81	2.75	3.54	4.52	5.74	6.64	7.33	7.87	8.68	9.25	9.67	10.0
U _{7ver.2} V	10.0	9.34	8.19	7.25	6.46	5.48	4.26	3.36	2.67	2.13	1.32	0.75	0.33	0

CONNECTION DIAGRAM

HIGH VOLTAGE COMPARTMENT

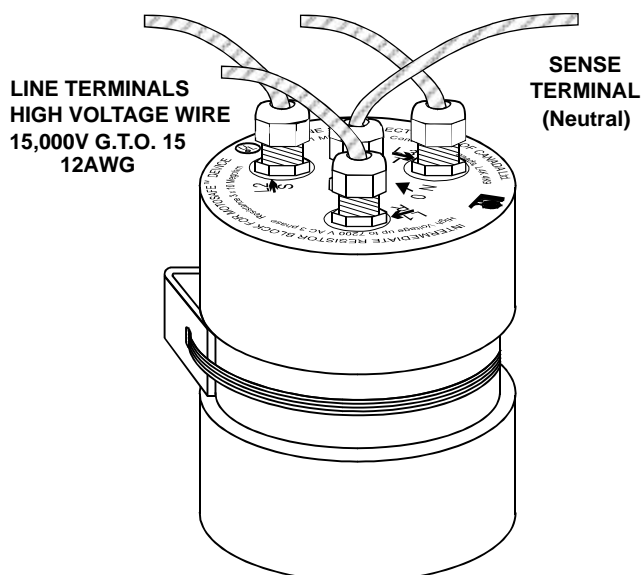

LOW VOLTAGE INSTRUMENT COMPARTMENT

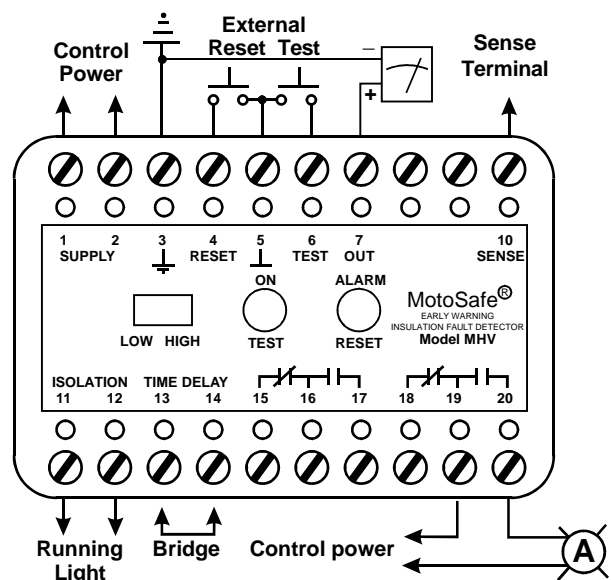

MOTOSAFE™ MONITOR MODEL MHV; INSTALLATION.

IMPORTANT: READ THE FOLLOWING INSTRUCTIONS BEFORE INSTALLING THE MONITOR.

MotoSafe INSULATION MONITOR TYPE MHV FOR DIRECT ON-LINE A. C. MOTORS UP TO 13.8kV.

The MotoSafe device continuously monitors the insulation resistance of idle machines and operates an alarm relay when the resistance falls below a set value. The recommended value for "Low" setting is 1Megohm per 1kV of the motor line voltage. The "High" setting should be higher for the purpose of early warning. For example the standard settings for MHV-13800 would be 14 & 20 Megohm.

THE INTERMEDIATE RESISTOR BLOCK

The Intermediate Resistor Block contains three high voltage resistors connected in star to form an artificial neutral. The three black leads connect the free ends of the resistors to the motor terminals and the red lead is used to connect the star point, which, under normal conditions, is at ground potential to the sense terminal (#10) of the Model MHV monitor. Should a ground fault occur on one of the phases, the star point potential increases to 57.7% of the phase voltage (7.97 kV for a 13.8 kV system), but the high resistance of the Intermediate Resistor Block limits the current which flows if the sense terminal becomes grounded to a maximum of 0.4 mA., which is not dangerous to personnel.

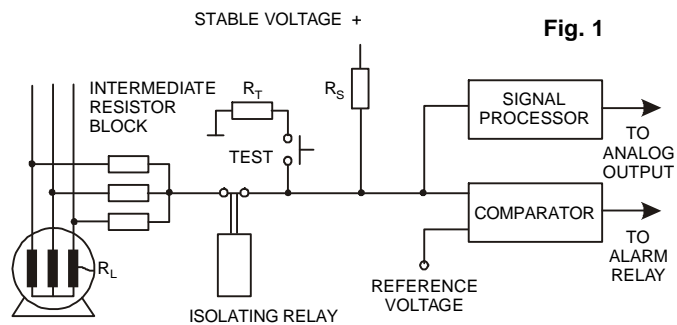

When the motor is idle, the isolating relay contacts are closed, as shown in Fig. 1. This connects the motor windings to a stable voltage source through the series resistor R_S . The series resistor and the generator windings leakage resistance R_L form a voltage divider with a comparator connected to the R_S / R_L junction. The voltage seen by the comparator is therefore a function of the value of the leakage resistance R_L which is indicated continuously at the analogue output. When this resistance falls below the set value, the comparator voltage falls below the reference voltage and the alarm relay is activated.

INSTALLATION INSTRUCTIONS

To install the MotoSafe device in the low voltage (instrumentation) compartment and the Intermediate Resistor Block in the high voltage compartment of the motor control enclosure:

1. Disconnect the power from the enclosure.
2. Fasten the monitor mounting bracket in place with the screws supplied. Clip the device securely to the bracket. If required (and regulations permit), install the long-life local alarm lamp (supplied) on the motor control front panel close to the hinges and affix the adhesive warning label around the lamp.
3. Install I R Block in the high voltage compartment using the mounting template and bracket provided.

WIRING INSTRUCTIONS

CAUTION: OBSERVE SAFETY PRECAUTIONS - DO NOT WORK ON LIVE CIRCUITS!

1. Disconnect the supply and control voltages.
2. Connect terminals 1 & 2 of the MotoSafe device to the control voltage supply as marked, terminals 11 & 12 across the breaker coil, auxiliary relay coil or running light (input may be AC or DC 24-300V), terminal 3 to ground and the common red lead on the Intermediate Resistor Block to terminal 10.
3. Connect the three line leads of I.R. Block firmly and directly to the lines between the contactor and the motor, according to high voltage safety practice and local regulations. Protect them from mechanical damage.
4. If a local alarm light is required, connect terminal 2 to 19 and the lamp between terminals 1 and 20. (Fig. 2)
5. Reconnect the supply and control voltages.

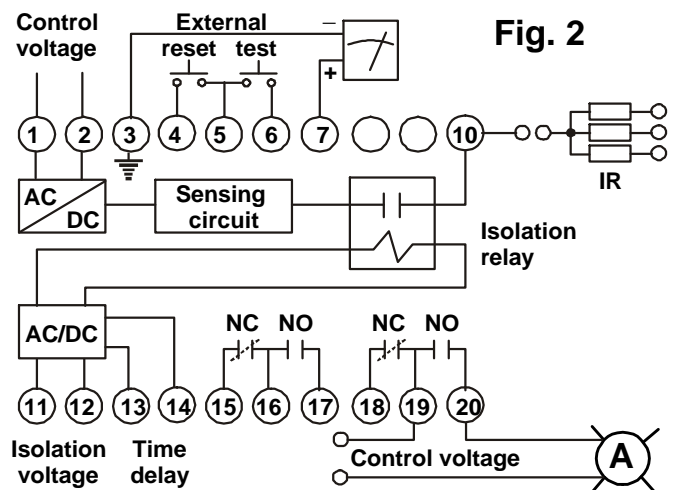

Note: Terminals 5 & 6 may be used to test the device and 4 & 5 to reset the alarm using external, NO push button switches. Terminals 13 & 14 are time delay terminals. Bridged, the unit senses the motor phases 50 seconds after the motor is stopped. Unbridged, there is a time delay of 8 minutes before sensing begins. The units are shipped with the terminals 13 & 14 bridged. Terminals 7 & 3 can be used for connection of the external meter or PLC for actual resistance reading.

TESTING

1. Ground one of the motor phases momentarily via the test resistor. The red LED should light and the external alarm circuit be activated after a delay of 10 seconds. Reset the monitor with the RESET button. Repeat this test with two other phases.
2. Start the motor. The red LED should NOT light and the external alarm devices should NOT operate.
3. Stop the motor. If the insulation resistance is satisfactory the alarm should not operate.

Note: The green LED indicates "Power ON" and the red LED is the alarm indicator. Should the alarm indicator light but the external alarm device does not, recheck the connections. If the connections are correct, test the contacts used for the external alarm (see Wiring Instruction #4) with a low range ohmmeter. If the results are not correct, replace the unit.

The analog output provides actual readings of the insulation resistance converted to 0 to 10V DC scale. Voltage at terminal 7 may be either zero for full ground and 10V for resistance of 70 Megohm or over (option 1) or 10V for full ground and zero for resistance 70 Megohm or over (option 2) depending on the option ordered. The relation between output voltage and resistance is:

for option 1 $U_7 = 20.12(6.66+R_L)/(17.66+R_L)-7.6$

and for option 2 $U_7 = 17.6-20.12(6.66+R_L)/(17.66+R_L)$

where R_L is the insulation resistance ($M\Omega$)

$R_L M\Omega$	0	1	3	5	7	10	15	20	25	30	40	50	60	70
$U_{7ver.1} V$	0	0.66	1.81	2.75	3.54	4.52	5.74	6.64	7.33	7.87	8.68	9.25	9.67	10.0
$U_{7ver.2} V$	10.0	9.34	8.19	7.25	6.46	5.48	4.26	3.36	2.67	2.13	1.32	0.75	0.33	0

The precision of the alarm settings and analog output is $\pm 5\%$

Connection Diagram Model MHV-13800

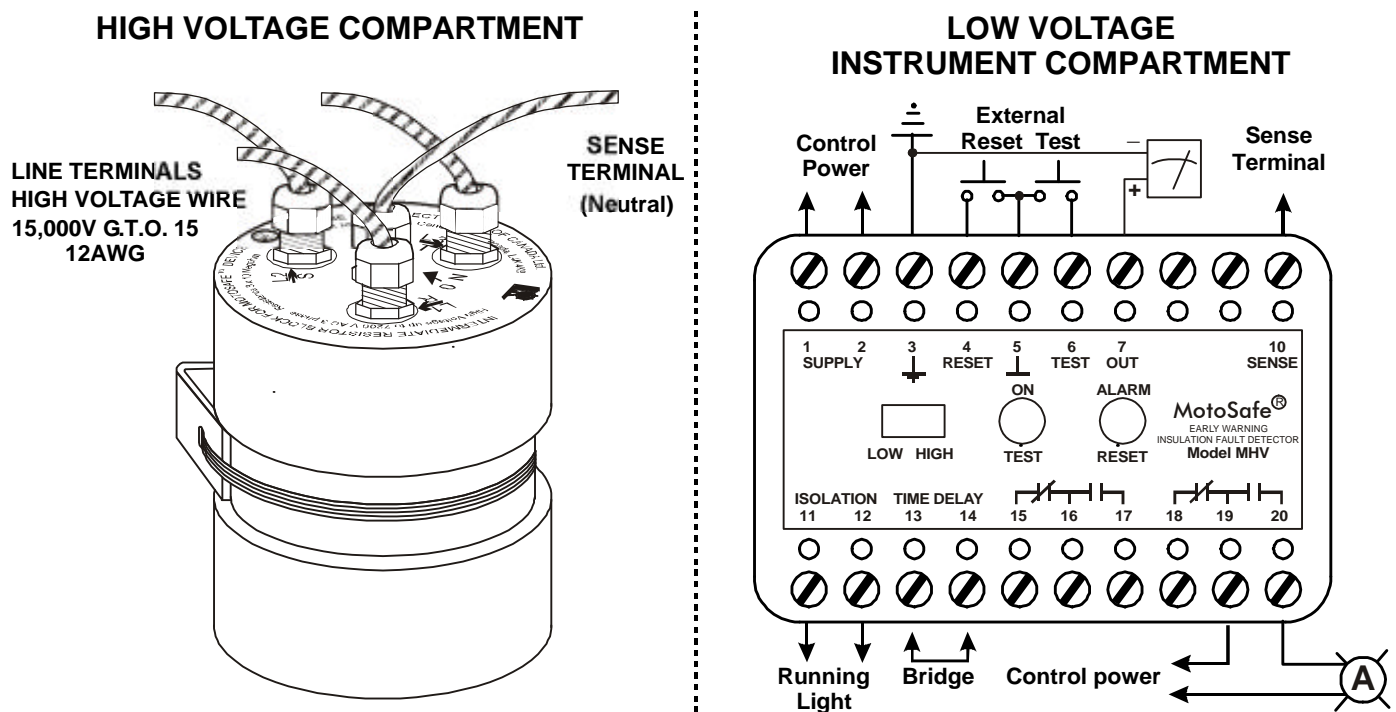

The Intermediate Resistor Block contains three high voltage precision resistors, connected in Star (WYE) configuration. During normal operation the neutral terminal will be close to ground potential. The resistors are protected by total encapsulation. This method of connection complies with all applicable codes and is approved by CSA and UL.

The device withstands the high voltage (to 5000V DC) applied by a Megger™ Tester. If a testing using higher voltage is required – disconnect the red sense wire from the sense terminal 10 of the monitor. Megger is the trademark of Megger Instruments Ltd.