



FailSafe®

MSE of Canada Ltd.

INSULATION MONITOR FOR THREE PHASE POWER SYSTEMS TYPE MG600 MODEL USM

The FailSafe Type MG 600 Model USM Insulation Monitors are intended for use in ships and are designed to meet Lloyds Type Certification and MIL Specification M-24678. The range of insulation resistance covered - 1 Megohm to 0.25 Megohms - was chosen to meet the needs of the marine environment, which is more severe than industrial environments. The monitors provide a visual alarm indication, with contacts for external alarm and other functions and are intended for use on small, ungrounded, three-phase AC power systems.

FEATURES:

- ✓ Easy Installation
- ✓ Small footprint DIN Rail mounting
- ✓ Completely automatic in operation
- ✓ Gives early warning of insulation problems
- ✓ Automatic alarm reset simplifies power system trouble-shooting
- ✓ High phase to ground impedance
- ✓ Solid state circuitry
- ✓ Integral self-test capability
- ✓ LED local alarm
- ✓ Contacts provided for local alarm and PLC connection

APPLICATION:

FailSafe Insulation Monitors Model USM are designed to monitor the electrical insulation integrity of energized, isolated and ungrounded three phase electrical power systems in the marine environment. The standard alarm levels offered are intended for the monitoring of small systems, although in principle they may be used to monitor power systems of any size. A typical application would be a lighting system fed by a 10 kva 480/120 volt, three phase transformer, for example and, with its remote indication capability, it would eliminate entirely the need for the conventional, low impedance, three-lamp ground indicator.

Like all FailSafe devices, the Model USM monitors insulation resistance and so is effective in detecting impending grounds on the ship's electrical system before they occur. The gradual decay of insulation resistance may be observed by using the three available alarm levels in the unit, switching to progressively lower alarm levels as the insulation deteriorates and noting the time intervals, to estimate the time remaining until the lowest level is reached.

This ability to give early warning of an impending ground fault on energized systems is unique to FailSafe Insulation Monitors Model USM.



ORDERING INFORMATION

Installation kit includes: the bracket DIN-MGM, the flashing alarm light, a Test Resistor, hook-up wire and wire connectors, Ty-wraps and mounting screws sufficient to install the unit, Explanatory and Warning labels.

SPECIFICATIONS

FailSafe Model USM

| | |
|--|--|
| Line voltage | 120V AC $\pm 20\%$ 50/60Hz 3 phase |
| Supply voltage | Derived from line voltage |
| Power requirements | 3 VA |
| Factory Setpoints* | 0.25, 0.5 & 1 MΩ |
| Contacts rating | 5 A, 250 V AC, resistive |
| Dimension (mm) WxHxL (in) | 45 x 68 x 112 1.77 x 2.67 x 4.4 |
| Weight (kg) / (oz) | 0.27 / 9.5 |

* For other setpoints - contact factory

- All units suitable for DIN Rail Mounting.
- Maximum short circuit current is 75 microampere.
- Temperature: operating -20° to $+50^{\circ}\text{C}$;
storage -40° to $+70^{\circ}\text{C}$.
- Environment maximum 95% relative humidity, non-condensing.
- UL and CSA approved as Industrial control device. Meets Lloyds and US Coast Guard requirements.

CONNECTION DIAGRAM

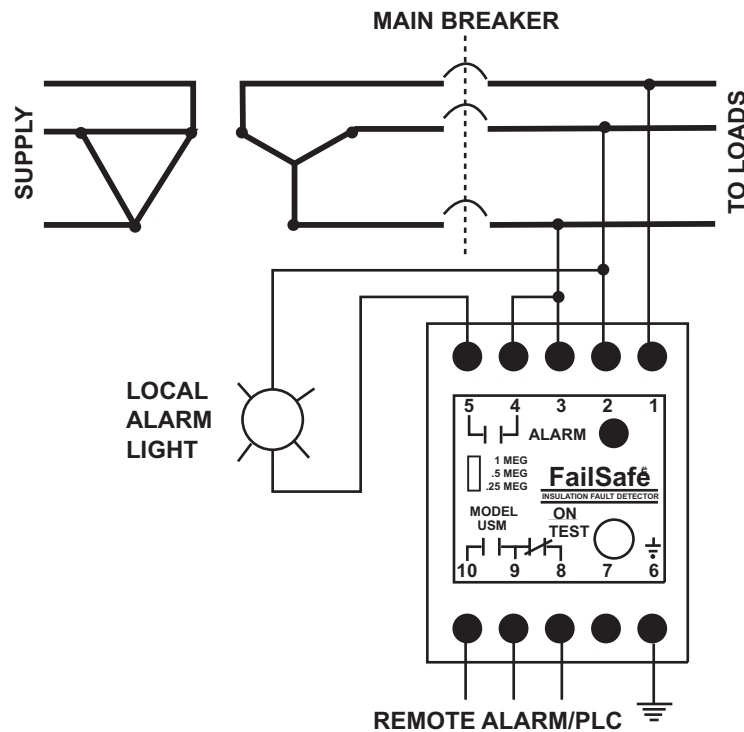

FailSafe™ MONITOR TYPE USM; INSTALLATION INSTRUCTION

IMPORTANT: READ THE INSTRUCTION BEFORE INSTALLING THE MONITOR

FailSafe INSULATION MONITOR FOR 3 PHASE UNGROUNDED SYSTEMS TYPE USM

The FailSafe device continuously monitors the leakage resistance of the power system and operates its alarm relay when the value falls below the chosen set point. The device includes a visual alarm indicator and provides two changeover contacts for eternal alarm indication.

OPERATION

The monitor is connected to each phase conductor of the system through three, star-connected resistors R_1 , R_2 and R_3 and a stabilized low DC voltage is applied to the star point through a range setting precision resistor and an AC filter. (See Fig. 1). The voltage appearing across the precision resistor is proportional to the system leakage resistance and its value is determined by comparing it to a reference voltage. When the value falls below the reference level, the alarm is activated and remains until the leakage resistance fault is removed.

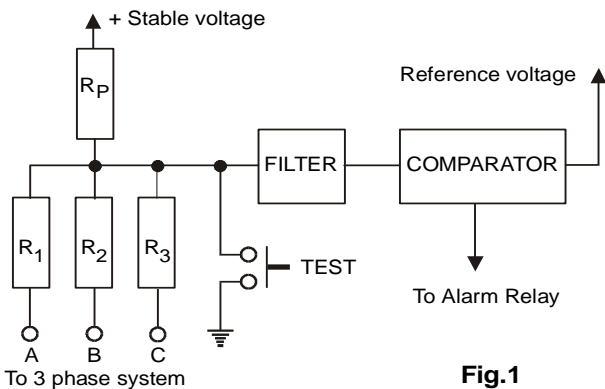

Fig.1

Note:

1. If any other device, which introduces a DC voltage between line and ground, is installed on the system, the alarm indication by the monitor will be incorrect.
2. If the system is to be meggered, the power line must be de-energized to obtain a correct reading. The device automatically disconnects from the ground.

INSTALLATION INSTRUCTIONS

To install the FailSafe monitor in the subdistribution panel:

1. Disconnect power from the panel.
2. Fasten the mounting bracket in place with the screws supplied. Clip the device securely to the bracket. If it is required, install the long life flashing alarm light on the panel door close to the hinges and affix the warning label around the lamp.

WIRING INSTRUCTIONS

CAUTION: OBSERVE SAFETY PRECAUTIONS - DO NOT WORK ON LIVE CIRCUITS!

1. Disconnect power from the panel.
2. Connect terminals A, B and C to the three phase bus bars through a suitable 3 phase fuse block. The lowest rating, eg. 2 amps, is suitable.
3. If a local alarm light is required, connect the supplied flashing alarm light to one of the phases (terminals B and C) via the normally open contact (terminals 4 and 5).
4. Connect terminal 6 to ground.
5. Terminals 8, 9 and 10 are for the dry type, changeover contact, which may be used to provide remote indication if, required.
6. Reconnect power to the panel.

TESTING

To test the installation:

1. Verify that the FailSafe monitor is not in alarm.
2. Ground one of the phases temporarily using the Test Resistor. After 2 seconds the red LED should light and the local alarm light should light also.
3. Remove the temporary ground. The red LED and the local alarm light should go out.
4. Repeat the test procedure for each of the remaining two phases. If all three phases operate as described, the installation is correct.

Connection Diagram Model USM

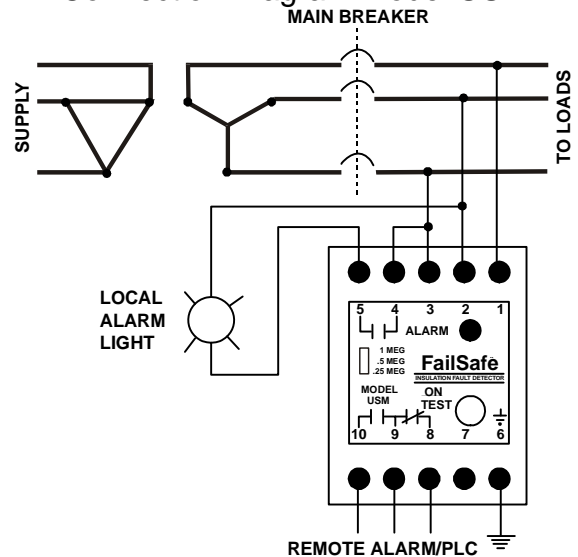

Note: The green LED is the "power ON" indicator and it is also the "TEST" push-button. After installation, the proper operation of the monitor, the local alarm light and the remote alarm indication (if installed) may be verified at any time by pushing the "TEST" button.